



MCG Grease Interceptor

Grease Interceptor

We understand the importance of maintaining a clean and efficient kitchen environment. That's why we offer top-of-the-line grease trap solutions designed to keep your business running smoothly. Our grease traps are engineered to effectively capture grease and food solids, preventing them from clogging your drains and causing costly disruptions to your operations.

Why Choose our Grease Traps?

Superior Performance: Our grease traps are built with advanced technology to ensure maximum efficiency in capturing grease and food waste.

Easy Maintenance: Designed for hassle-free maintenance, our grease traps are easy to clean and maintain, saving you time and effort.

Compliance Assurance: We understand the importance of compliance with local regulations. Our grease traps are designed to meet or exceed regulatory standards, keeping your business in good standing.

Cost Savings: By preventing grease buildup in your pipes, our grease traps help you avoid costly plumbing repairs and downtime, ultimately saving you money in the long run.

Product Range:

Standard Grease Traps: Ideal for small to medium-sized establishments, our standard grease traps offer reliable performance at an affordable price.

High-Capacity Grease Traps: Designed for high-volume kitchens, our high-capacity grease traps can handle large amounts of grease and food waste without compromising efficiency.

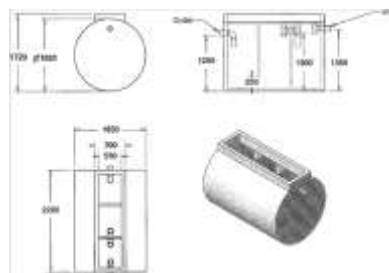
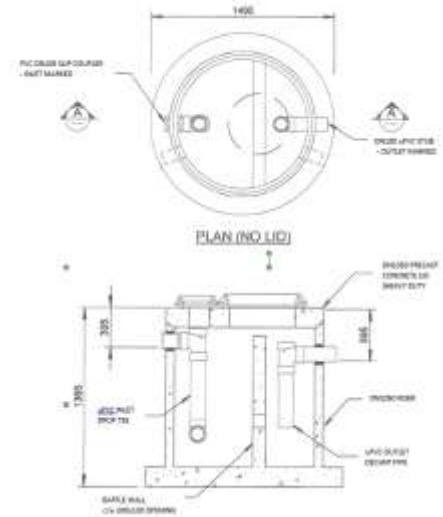

MCG

McDONALD
CONCRETE
GROUP